



Rack Installation Instructions for the IBM UPS3000 LV, UPS3000 HV, and UPS3000 Extended Battery Module

Use the instructions in this document to install the IBM® UPS3000 LV or IBM UPS3000 HV (uninterruptible power supply) or the IBM UPS3000 EBM (extended battery module) in a rack cabinet.

Review the documentation that comes with your rack cabinet for safety and cabling information. When installing your system in a rack cabinet, consider the following:

- Make sure that the room air temperature is below 35°C (95°F).
- Do not block any air vents, usually 15 cm (6 in.) of air space provides proper airflow.
- Plan the device installation starting from the bottom of the rack cabinet.
- Install the heaviest device in the bottom of the rack cabinet.
- Do not extend more than one device out of the rack cabinet at the same time.
- Connect all power cords to properly wired and grounded electrical outlets.
- Do not overload the power outlet when installing multiple devices in the rack cabinet.

You can install the uninterruptible power supply or extended battery module in a 19-inch rack cabinet that is 24 to 30 in. deep.

You will need a flat-blade and a number 2 Phillips screwdriver during the installation.

Use cage nuts for rack cabinets with square holes, and use clip nuts for rack cabinets with round holes. If your rack cabinet requires cage nuts, use a cage-nut-insertion tool or a flat-blade screwdriver to install them.

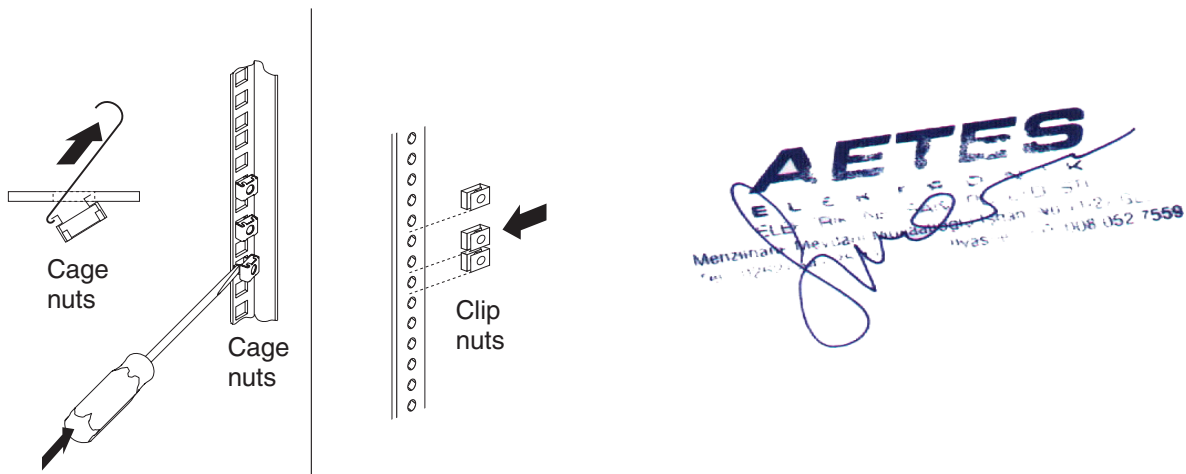

Important: You must install the uninterruptible power supply and extended battery module at the bottom of the rack cabinet. Install the extended battery module below the uninterruptible power supply.

To install the uninterruptible power supply or extended battery module in a rack cabinet, complete the following steps:

1. Loosen the assembly wing nuts on the left and right rail assemblies and adjust the rail size for the depth of the rack cabinet.

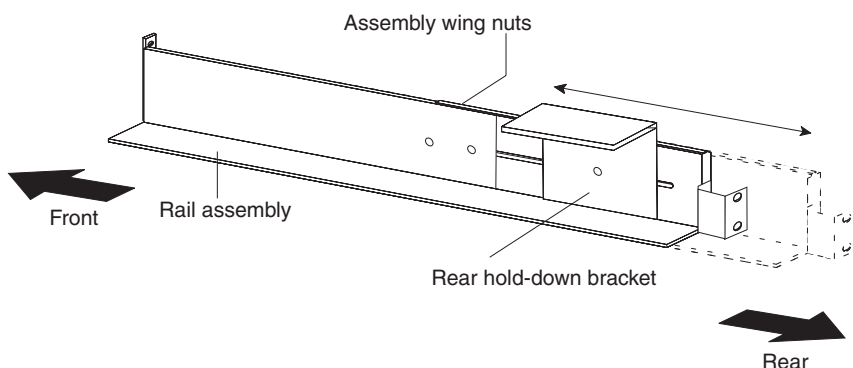

2. If you are shipping the rack cabinet with the uninterruptible power supply and extended battery modules installed, you must secure the units in the rack cabinet with the rear hold-down brackets that come with the rail kit. To attach the rear hold-down bracket to the rail assembly, align the bracket toward the rear of the rail and attach it with one wing nut from the rail kit.
3. Select a location in the bottom of the rack cabinet for the uninterruptible power supply or extended battery module. On the rack cabinet rear only, install either cage nuts or clip nuts on the rack cabinet using the following illustration to guide you. Use the cage nuts or clip nuts from the miscellaneous hardware kit.

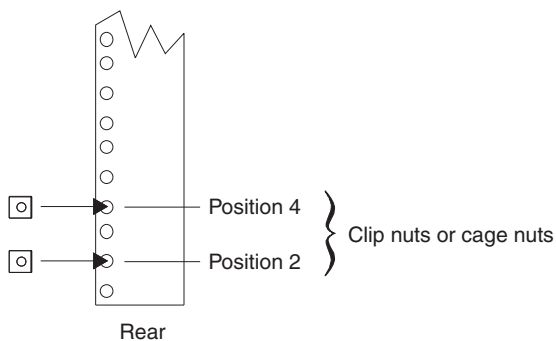

4. Attach the rail to the rear of the rack cabinet using two M5 (hex-head) screws.

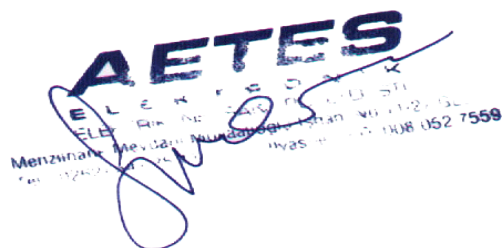
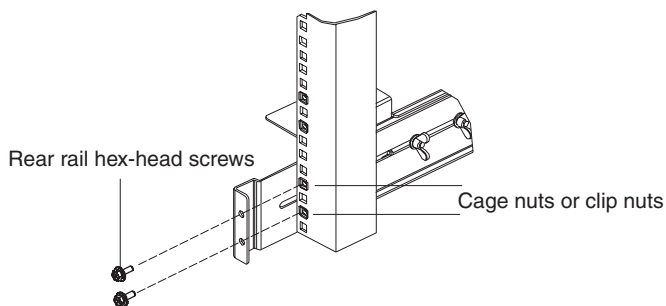

5. If the rack cabinet has square holes, you must attach the adapter plate that comes with the rail kit. Align the adapter plate with the holes in the front of the rack cabinet. Make sure that the embossed side of the adapter plate is towards the rack cabinet.

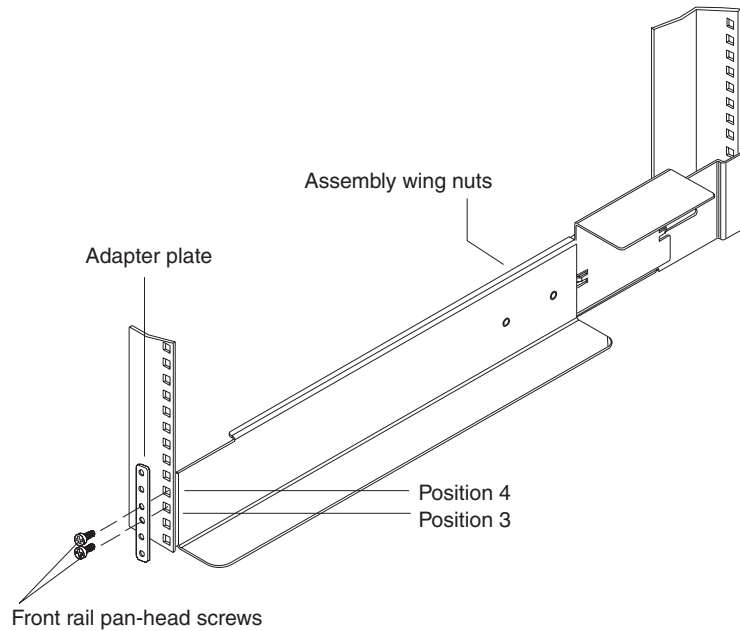

6. Attach the rail to the front of the rack cabinet with two #10-32 pan-head screws.
7. Repeat step 4 on page 2 through step 6 for the other rail.
8. Tighten the assembly wing nuts on both rail assemblies.



CAUTION:

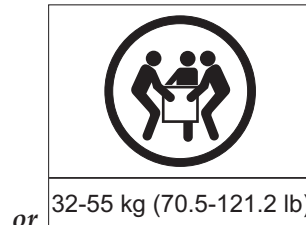
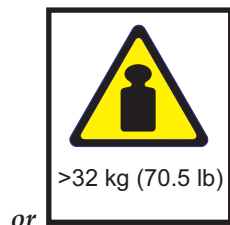
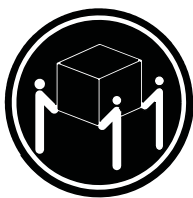

The weight of this part or unit is between 32 and 55 kg (70.5 and 121.2 lb). It takes three persons to safely lift this part or unit. (C010)

9. To install the handles on the uninterruptible power supply or an extended battery module, complete the following steps:
 - a. Place the uninterruptible power supply or extended battery module on a flat, stable surface with the front facing toward you.

Important:

- The uninterruptible power supply weighs approximately 38 kg (84 lb); therefore, three people are required to lift it.
- The extended battery module weighs approximately 52 kg (115 lb); therefore, three people are required to lift it.

- b. Attach the mounting handles that come with the uninterruptible power supply or extended battery module to the mounting brackets and secure with the screws that come with the unit.

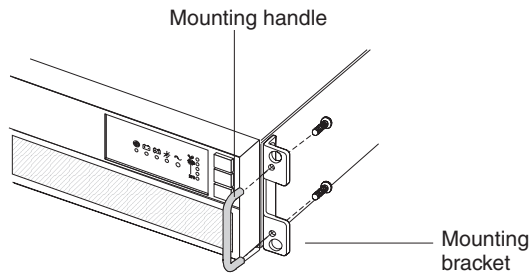

10. Slide the uninterruptible power supply or extended battery module into the rack cabinet. Make sure that you install the extended battery module below the uninterruptible power supply.

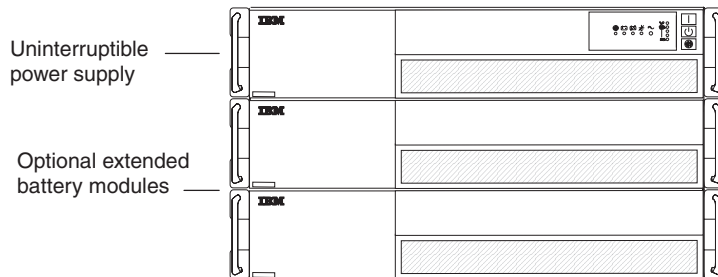

11. Secure the front of the uninterruptible power supply or extended battery module to the rack cabinet using four #10-32 pan-head screws.

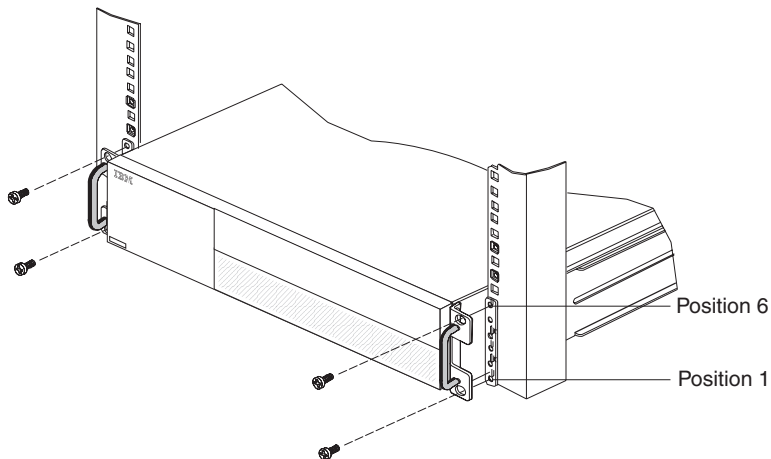

AETES
 ELEKTRONIK
 Menzinger Meydanı No: 10/108 052 7559
 Tel: 0212 212 12 12

12. If you are shipping the rack cabinet with the uninterruptible power supply and extended battery modules, loosen the wing nut on the rear hold-down bracket and slide the bracket over the rear of the unit; then, tighten the wing nut.

